

Ventilation Screws

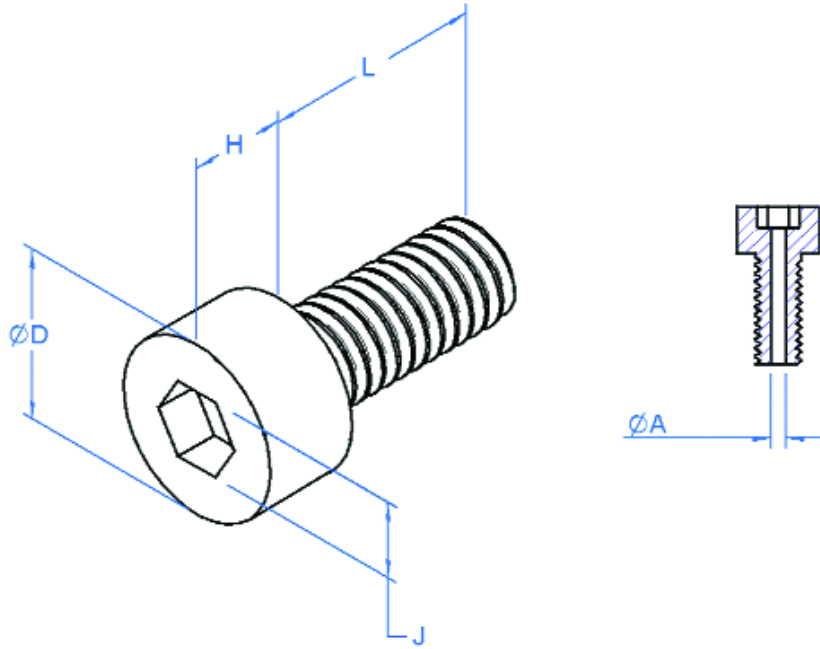

General Information

All dimensions in mm
 Thread Specification:
 BS3643: Pt.2 1981
 Tolerance class: 6g.
 Material:
 A2-70 Austenitic⁽¹⁾
 A4-70 Austenitic⁽²⁾
 Stainless steel to
 ISO 3506-1: 1997

Associated Products

Disc springs
 Nuts and washers

Visit our online catalogue for associated products

Part number selection table

Example Part No:- S - M3 - 12 - A47 - AD

Basic Part No.	Std Thd Size	ØD max	H max	J nom	ØA ±0.05	Standard Length L								Matl.	
						3	4	5	6	8	10	12	16		20
S	M1.6	3.0	1.6	1.5	0.6	3	4	5	6						A27 ⁽¹⁾
	M2	3.8	2.0	1.5	0.7	4	5	6	8						A47 ⁽²⁾
	M2.5	4.5	2.5	2.0	0.8		5	6	8	10					
	M3	5.5	3.0	2.5	1.0		6	8	10	12	16	20			
	M4	7.0	4.0	3.0	1.0			8	10	12	16	20	25		
	M5	8.5	5.0	4.0	1.5				10	12	16	20	25	30	
M6	10.0	6.0	5.0	1.5					12	16	20	25	30	40	

- Socket head cap screw in accordance with ISO 4762 drilled through on axis for use in vacuum assemblies to assist cavity ventilation.
- Rolled thread for excellent surface finish, superior thread strength and increased hardness properties.

Non-standard options, please enquire....

- Slotted head.
- Imperial sizes.
- Alternative materials.

www.rpmechatronics.co.uk