

Clamp Cleats

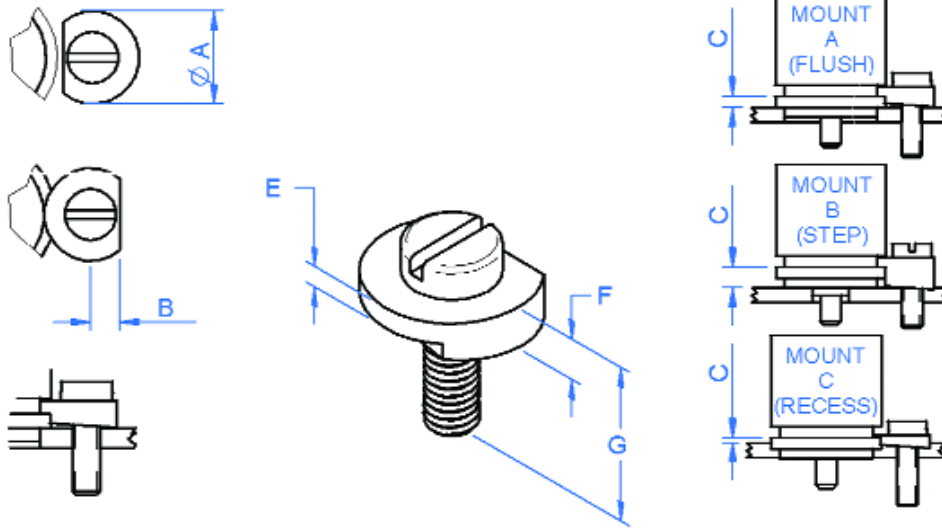

General Information

All dimensions in mm
 General tolerances:
 ±0.13mm
 Materials:-
 Stainless steel clamp.
 Nylon locking insert.

Associated Products

Gearboxes
 Adaptor plates

Visit our online catalogue for associated products

Part number selection table

Part Number	Mount Type	Height C ±0.08	Flat B	Lip E ±0.08	Height F	Length G +0.0/-0.8	Thread Size	O/D ØA +0.00/-0.13
SQM-6	A & C	0.79	3.18	1.02	1.8	7.0	M3 x 0.5	9.90
SQM-7	A	1.57		1.02	2.59			
SQM-8		1.57		1.27	2.84			
SQM-9		1.57		1.60	3.18			
SQM-10		1.98		1.60	3.58			
SQM-11		2.36		1.02	3.38			
SQM-12		2.36		1.27	3.63			
SQM-13		2.36		1.60	3.96			
SQM-14		B		3.18	1.27	4.45		
SQM-15				3.96	1.02	4.98		
SQM-16				5.72	1.60	7.32		
SQM-17	A	6.35		1.60	7.92	15.0		

- Ideal for use with resolvers, encoders and potentiometers.

Non-standard options, please enquire....

- Imperial sizes.
- Alternative materials.

www.rpmechatronics.co.uk