



# Clamp Hub Spur Gear

6 - 12mm Bore

## General Information

All dimensions in mm  
General tolerances:  
±0.13mm

Material:  
Stainless steel  
or  
Aluminium alloy

Pressure angle 20°

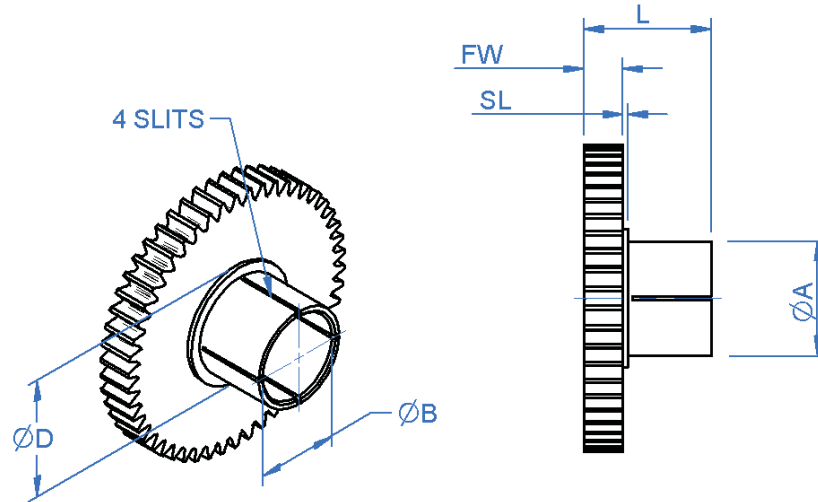

## Associated Products

Anti-backlash gears  
Shafts  
Bearings  
Gear clamps

Visit our online catalogue for associated products

## Drawing dimension table

Bore Size Nom	Bore Dia ØB	Overall Length L	Gear Face width FW	Clamp Dia ØA	Shoulder Dia ØD	Shoulder Length SL	Recommended Clamp #
6	6.003	10	3	7.60	10.40	0.50	CGAM-6A
	5.995	11	4	7.56	9.60		
		13	6				
8	8.003	13	4	9.60	12.40		CGAM-8A
	7.995	15	6	9.56	11.60		
10	10.003	13	4	11.60	14.40		CGAM-10A
	9.995	15	6	11.56	13.60		
12	12.003	15	6	13.60	16.40		CGAM-12A
	11.995	19	10	13.56	15.60		

# see gear clamps on page 53 for information.

- Standard gear quality AQ10 - see page 56.
- Material and treatment specifications - see page 59.

## Non-standard options, please enquire....

- Higher gear qualities - see page 56.
- Alternative modules.
- Imperial diametral pitches.
- Imperial bore sizes 1/4", 5/16", 3/8" & 1/2".
- Larger numbers of teeth.

www.rpmechatronics.co.uk

Standard Product Sales : ☎ +44 (0)1484 601060 📠 +44 (0)1484 601061  
www.rpmechatronics.co.uk sales@rpmechatronics.co.uk

© Reliance Precision Mechatronics LLP



Part number selection table

Example Part No:- <u>C06S1B6</u> <u>F2A-</u> <u>32</u>						
Bore Size Nom	Standard Modules	Basic Part Number Standard Materials		Face Width	Number of Teeth	
		Stainless Steel	Aluminium Alloy	Dim FW	Min	Max
6	0.6	C06S1B6	C06A1B6	F3A- (3mm)	20	25#
	0.5	C05S1B6	C05A1B6		22	29#
	0.4	C04S1B6	C04A1B6	F4A- (4mm)	25	36#
	0.3	C03S1B6	C03A1B6		30	47#
	0.25	C025S1B6	C025A1B6	F6A- (6mm)	34	56#
	0.2	C02S1B6	C02A1B6		40	69#
8	0.6	C06S1B8	C06A1B8	F4A- (4mm)	24	30#
	0.5	C05S1B8	C05A1B8		26	35#
	0.4	C04S1B8	C04A1B8	F6A- (6mm)	30	43#
	0.3	C03S1B8	C03A1B8		37	57#
	0.25	C025S1B8	C025A1B8	F6A- (6mm)	42	68#
	0.2	C02S1B8	C02A1B8		50	84#
10	0.6	C06S1B10	C06A1B10	F4A- (4mm)	27	36#
	0.5	C05S1B10	C05A1B10		30	43#
	0.4	C04S1B10	C04A1B10	F6A- (6mm)	35	53#
	0.3	C03S1B10	C03A1B10		44	70#
	0.25	C025S1B10	C025A1B10	F6A- (6mm)	50	84#
	0.2	C02S1B10	C02A1B10		60	104#
12	0.6	C06S1B12	C06A1B12	F6A- (6mm)	30	127
	0.5	C05S1B12	C05A1B12		34	152
	0.4	C04S1B12	C04A1B12	F10A- (10mm)	40	190
	0.3	C03S1B12	C03A1B12		50	254
	0.25	C025S1B12	C025A1B12	F10A- (10mm)	58	304
	0.2	C02S1B12	C02A1B12		70	381

**General Information**

All dimensions in mm  
 General tolerances: ±0.13mm  
 Material:  
 Stainless steel or Aluminium alloy  
 Pressure angle 20°

**Associated Products**

Anti-backlash gears  
 Shafts  
 Bearings  
 Gear clamps  
 Visit our online catalogue for associated products

www.rpmechatronics.co.uk

# For greater numbers of teeth, see Reli-a-Grip™ gears on page 26. Although larger numbers of teeth are available on this style if required.

