



# Worms & Wheels

0.5 Module

## General Information

All dimensions in mm  
 General tolerances:  
 ±0.5mm  
 Material:  
 Stainless steel  
 (DIN 1.4305) worm.  
 Brass (Naval  
 QQ-B-637) wheels.

Pressure angle 14.5°  
 Right hand.

## Associated Products

Shafts  
 Bearings

Visit our online  
 catalogue for  
 associated products

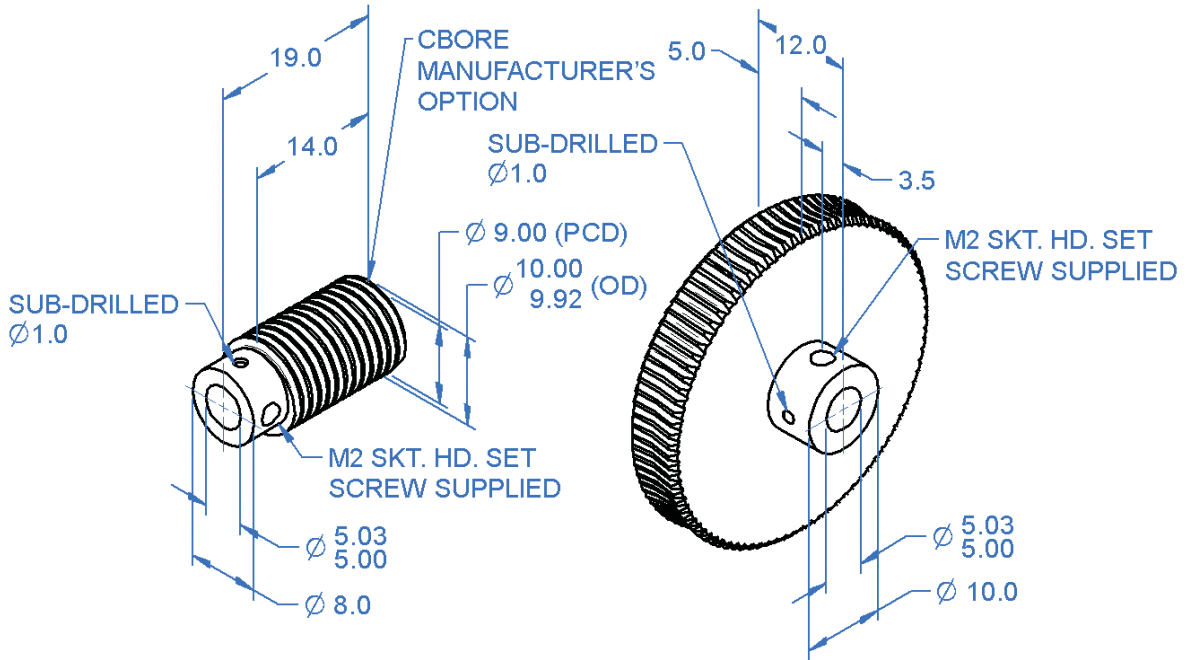

## Part number & drawing dimension table

Worm		Wormwheel		
Lead Angle	3° 10'	Part Number	Number of Teeth	Pitch Diameter
Lead	1.571	WFB83-S30	30	15.00
P.A.	14.5°	WFB83-S40	40	20.00
Part Number	WFS-5S	WFB83-S50	50	25.00
		WFB83-S60	60	30.00
		WFB83-S70	70	35.00
		WFB83-S80	80	40.00
		WFB83-S90	90	45.00
		WFB83-S100	100	50.00
		WFB83-S120	120	60.00

- Accuracy AQ10 - see page 56.
- Material and treatment specifications - see page 59.
- See page 45 for worm gear formulae.

## Non-standard options, please enquire....

- Higher accuracies.
- Anti-backlash.
- Alternative number of starts

www.rpmechatronics.co.uk

Standard Product Sales : ☎ +44 (0)1484 601060 📠 +44 (0)1484 601061  
 www.rpmechatronics.co.uk sales@rpmechatronics.co.uk

© Reliance Precision Mechatronics LLP