



# Pinion Shafts

Single End

## General Information

All dimensions in mm  
 General tolerances:  
 $\pm 0.13\text{mm}$   
 Material:  
 Stainless steel 303  
 Pressure angle  $20^\circ$

## Associated Products

Spur gears  
 Bearings  
 Reli-a-Flex™ couplings

Visit our online catalogue for associated products

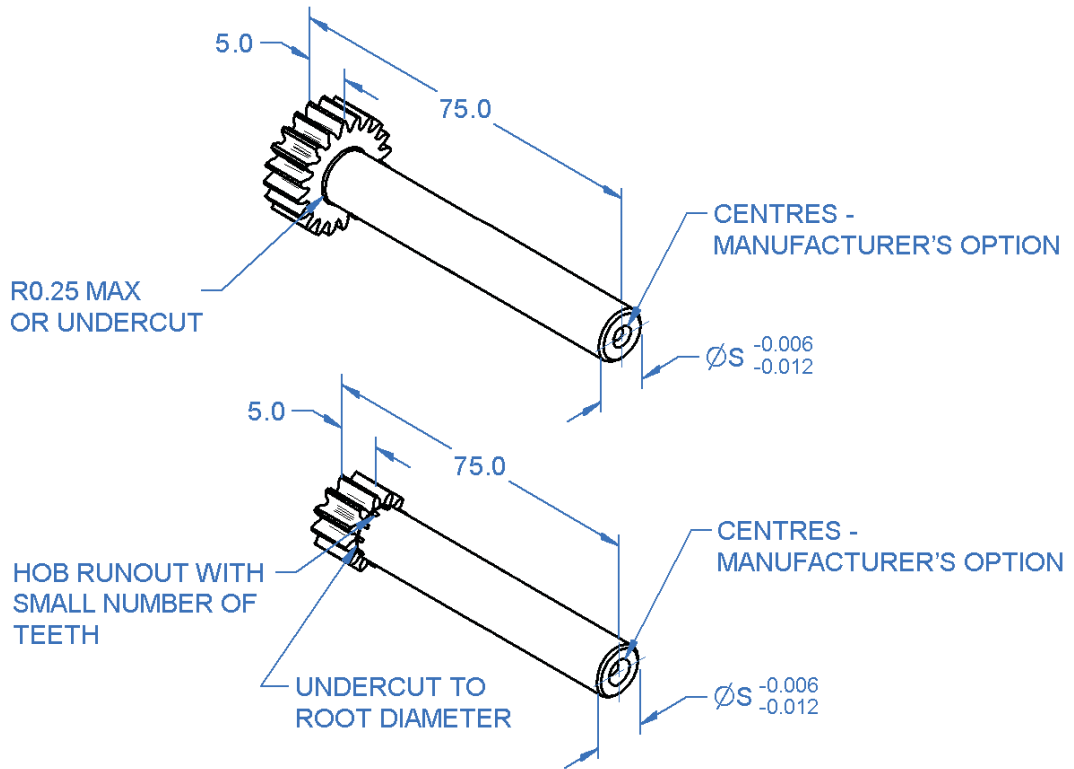

## Part number selection table

| Shaft Diameter, $\text{ØS} = 4.0$    |        |                 |           | Shaft Diameter, $\text{ØS} = 6.0$    |        |                 |           |
|--------------------------------------|--------|-----------------|-----------|--------------------------------------|--------|-----------------|-----------|
| Example Part No:- <b>5PS4T06- 12</b> |        |                 |           | Example Part No:- <b>5PS6T06- 20</b> |        |                 |           |
| Basic Part Number                    | Module | Number of Teeth |           | Basic Part Number                    | Module | Number of Teeth |           |
|                                      |        | Min             | Max       |                                      |        | Min             | Max       |
| <b>5PS4T06</b>                       | 0.6    | <b>12†</b>      | <b>18</b> | <b>5PS6T06</b>                       | 0.6    | <b>12†</b>      | <b>31</b> |
| <b>5PS4T05</b>                       | 0.5    | <b>12†</b>      | <b>22</b> | <b>5PS6T05</b>                       | 0.5    | <b>12†</b>      | <b>38</b> |
| <b>5PS4T04</b>                       | 0.4    | <b>14†</b>      | <b>28</b> | <b>5PS6T04</b>                       | 0.4    | <b>14†</b>      | <b>48</b> |
| <b>5PS4T03</b>                       | 0.3    | <b>16†</b>      | <b>38</b> | <b>5PS6T03</b>                       | 0.3    | <b>16†</b>      | <b>64</b> |
| <b>5PS4T025</b>                      | 0.25   | <b>16†</b>      | <b>46</b> | <b>5PS6T025</b>                      | 0.25   | <b>20</b>       | <b>78</b> |
| <b>5PS4T02</b>                       | 0.2    | <b>16†</b>      | <b>58</b> | <b>5PS6T02</b>                       | 0.2    | <b>22</b>       | <b>98</b> |

† Gears of 16 teeth or fewer will be modified - see technical section, page 63.

- Standard gear quality AQ10 - see page 56.
- Material and treatment specifications - see page 59.

## Non-standard options, please enquire....

- Higher gear qualities - see page 56.
- Alternative modules.
- Imperial diametral pitches.
- Shorter shaft lengths.

Standard Product Sales : ☎ +44 (0)1484 601060 📠 +44 (0)1484 601061  
[www.rpmechatronics.co.uk](http://www.rpmechatronics.co.uk) [sales@rpmechatronics.co.uk](mailto:sales@rpmechatronics.co.uk)

© Reliance Precision Mechatronics LLP