

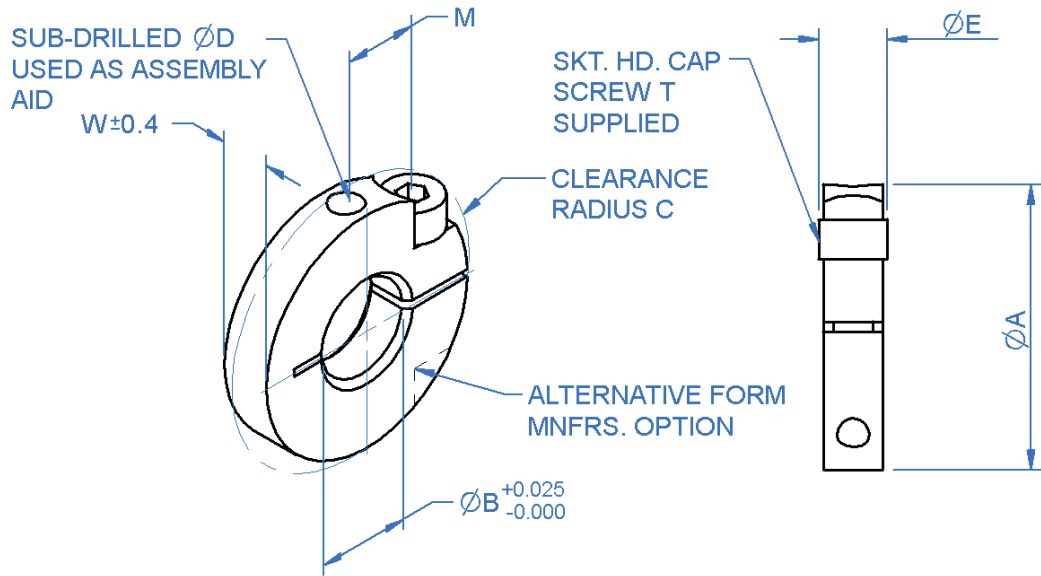

Gear Clamps



General Information

All dimensions in mm
 General tolerances:
 ±0.13mm
 Material:
 Stainless steel 303

Associated Products

Clamp hub gears

Visit our online catalogue for associated products

www.rpmechatronics.co.uk

Part number selection table

Part Number	To suit gear of bore dia	Bore ØB	O.Dia ØA	Width W	Head dia ØE (max)	Clearance radius C	Screw supplied T	Screw offset M	Sub-drill ØD
CGM1-2	2	3.6	16.0	4.0	3.8	8.7	M2	5.3	1.5
CGM1-3	3	4.6							
CGM1-4	4	5.6	22.0	5.0	5.5	12.8	M3	7.5	3.0
CGM1-5	5	6.6							
CGM1-6	6	7.6							
CGM1-8	8	9.6	29.0	6.0	7.0	17.1	M4	9.5	4.0
CGM1-10	10	11.6							
CGM1-12	12	13.6							
			32.0	7.0		18.0		11.0	

- Used with standard clamp hub style gears and pinions.

Non-standard options, please enquire....

- Imperial bores.

Standard Product Sales : ☎ +44 (0)1484 601060 📠 +44 (0)1484 601061
 www.rpmechatronics.co.uk sales@rpmechatronics.co.uk

© Reliance Precision Mechatronics LLP